

This manual is for reference and historical purposes, all rights reserved.

This page is copyright© by M. Butkus, NJ.

This page may not be sold or distributed without the expressed permission of the producer

I have no connection with any camera company

On-line camera manual library

This is the full text and images from the manual. This may take 3 full minutes for the PDF file to download.

If you find this manual useful, how about a donation of \$3 to: M. Butkus, 29 Lake Ave., High Bridge, NJ 08829-1701 and send your e-mail address so I can thank you. Most other places would charge you \$7.50 for a electronic copy or \$18.00 for a hard to read Xerox copy.

This will allow me to continue to buy new manuals and pay their shipping costs.

It'll make you feel better, won't it?

**If you use Pay Pal or wish to use your credit card,
click on the secure site on my main page.**



VITOMATIC I

24 x 36 · 35 mm

INSTRUCTIONS FOR USE



Right Here

is the first and most important piece of advice for the VITOMATIC: Please read this booklet carefully. Make yourself thoroughly familiar with all the operations and controls of the camera. Then you can load your first film and begin to take pictures.

Remember also that the VITOMATIC is an optical and mechanical precision instrument which requires gentle and sensible treatment. The camera will repay careful handling with beautifully clear and sharp pictures for many years to come.

VOIGTLÄNDER A. G. BRAUNSCHWEIG



The 2 inch (50 mm.) COLOR-SKOPAR f/2.8

fitted to your camera is a four-element unit, and is one of the series of Voigtländer high-class anastigmat lenses. It meets every requirement for optimum image quality: excellent definition, high brilliance, and maximum resolution over the whole picture area – coupled with absolutely faithful colour rendering in colour photography.

- The Color-Skopar is focused by the movement of the whole lens system as a self-contained optical and mechanical unit. It goes without saying that all air-glass surfaces are hard-coated with a vacuum evaporated anti-reflection layer.

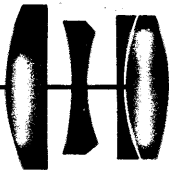

VITOMATIC I

24 x 36 — 35 mm

- 1 **Dot divisions** on setting ring (5) for filter factor adjustment
- 2 **Viewfinder window**
- 3 **Rewind knob with film indicator**
- 4 **Reversing lever**
- 5 **Universal setting ring** for exposure readings, combined with film speed setting ring
- 6 **Shutter speed ring**
- 7 **Honeycomb cell window** of exposure meter
- 8 **Exposure meter setting window**
- 9 **Release button** with cable release socket
- 10 **Accessory shoe**
- 11 **Depth of field scale**
- 12 **Setting window (DIN)** for film speeds
- 13 **Shutter speed scale**
- 14 **Synchronizing lever** for M and X synchronization and self-timer (V)
- 15 **Lens focusing ring** for setting the distance
- 16 **Distance scale**
- 17 **Aperture scale**
- 18 **Setting marker of exposure meter**
- 19 **Exposure meter needle**

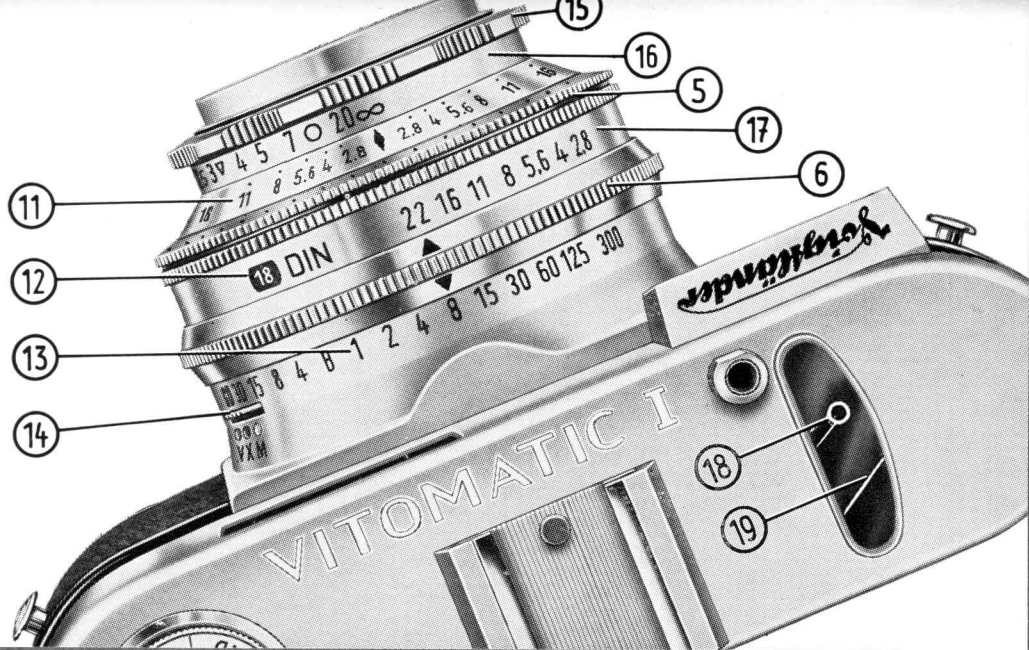

	Page
<i>Contents</i> Opening the camera and inserting the film	2-4
Setting the film counter	5
Unloading the camera	6
Changing partly exposed films	7
Setting shutter speeds and apertures	8-11
The self-timer (delayed action release)	11
Setting the distance	12
Zone focusing	13
The rapid winder - the double exposure lock ..	14
Viewing and releasing	15
Flash exposures	16-19
Using filters	20-21
Close-ups with the supplementary Focar lenses ..	22
Hints for using the exposure meter	23-27
Aperture and depth of field	28

Loading and unloading the Camera

Standard 35 mm. miniature film for 24 x 36 mm. negatives is commercially available as black-and-white as well as colour film in daylight cassettes of 36 or 20 exposures.

Although the cassettes are light-tight, it is advisable not to expose them to strong light. Make a point therefore of always loading and unloading the camera in the shade – even the shadow of your own body will do.

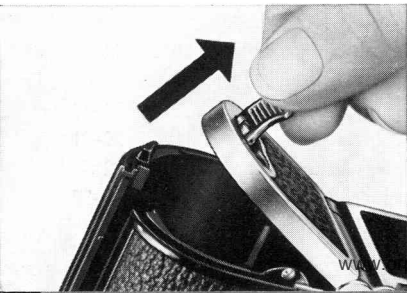

➔ **Opening the Back**

First lift up the base plate latch (25), and turn it through a quarter turn to the right. Then fold away the base plate flap (26) as shown in the illustration, and swing open the back from the body.

➔ Inserting the Cassette

- Pull out a short length of the film leader from the cassette, and push it into the slit of the take-up spool (32) as far as it will go (see illustration).
- Draw the cassette across the film track, and insert it in the cassette chamber (29). The shaft (28) of the rewind knob must properly engage the cassette, otherwise you will not be able to close the camera later on.
- Now push the reversing lever (4) backwards (making the rewind knob (3) jump up), and keep pulling out the rapid winding lever (30) until the film leader is firmly rolled round the take-up spool, and the transport sprocket (31) engages the film perforations. Then push the rewind knob back again.

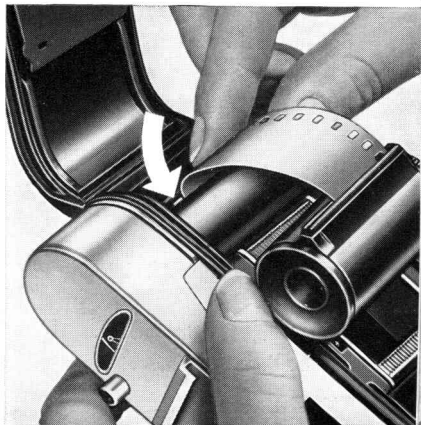

Before closing, the loaded camera must appear as shown in the illustration on the right. The film lies flat in the film track, with the teeth of the transport sprocket engaging the film perforations.

➔ **Closing the Camera Back**

First push the back against the body, then press the base plate flap (26) into position, turn the base plate latch (25) to lock it, and fold down.

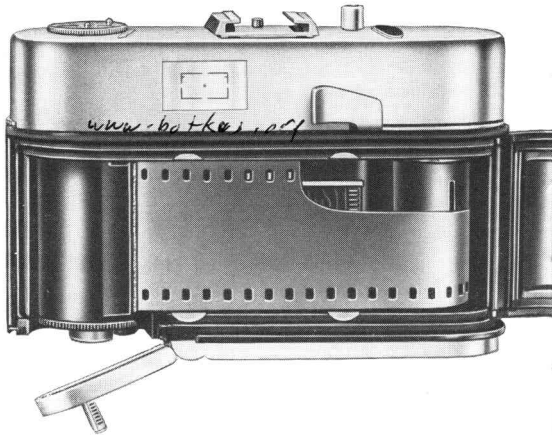

▶ Setting the Film Counter

Every time the film is advanced, the film counter shows the number of exposures still available. It thus runs backwards from No. 36 or 20 (the first exposure) to No. 1.

With 36-exposure cassettes: Turn the milled knob (21) until the red letter "F" appears below the index mark (a). Pull the rapid winder (30) once or twice until it locks, press the release button (9), and once more work the rapid winder until it locks again. The red figure 36 is now opposite the index mark (b), and the film is ready for the first exposure.

With 20-exposure cassettes: Turn the milled knob (21) until the red figure 22 is opposite the index mark (c). Then proceed as above until the figure 20 appears in the film counter window (d) for the first exposure.

The film indicator in the rewind knob (3) is intended solely as a memory aid. Set it by turning to the appropriate symbol:

- RD (UT) = Daylight type reversal colour film
- RA (UK) = Artificial light type reversal colour film
- ND (NT) = Daylight type negative colour film
- NA (NK) = Artificial light type negative colour film
- N (Z) = Black-and-white negative film
- R (U) = Black-and-white reversal film



➔ Unloading

After the last frame the exposed film must be rewound from the take-up spool into the daylight cassette:

Push back the reversing lever (4); the rewind knob (3) will spring up into its operating position (see illustration).

Turn the rewind knob in the direction of the arrow while observing the film counter window. The film counter now runs back from No. 1 (last exposure). When after No. 36 or 20 the red letter "F" or the red mark for No. 22 respectively is below the index mark, the film is fully rewound. The cassette can then be removed from the camera.



Changing Partly Exposed Films

With the VITOMATIC you can at any time take out a partly exposed film and change over to another one (e. g. from black-and-white to colour) without the need for a darkroom:

- Rewind the partly exposed film into its cassette, as already described on page 6. Make a note, however, of the last number that appeared in the film counter window.
- When re-inserting the partly exposed film, proceed in the same way as described on pages 3 to 5 up to setting the film counter to "F" or to No. 22.
- Then push back the reversing lever (4), letting the rewind knob (3) spring up. Keep pulling the rapid winding lever (30) fully to the right until the number following the number originally noted appears in the film counter window (22) below the red index mark.

Finally push back the rewind knob (3), pull the rapid winding lever (30) once more as far as it will go, and carry on exposing the film in the normal way.

The Perfect Automatic Exposure System

of this camera gives you at the same time the maximum certainty of correctly exposed pictures, and a hitherto inconceivable simplification in operation.

I A single turn of the universal setting ring covers the whole aperture-speed scale in one continuous range, and brings the setting pointer of the exposure meter to co-incide with the meter needle at any reading.

In other words, without having to engage or disengage any sort of coupling, and completely independently of the shutter speed or aperture set, you in effect use the shutter to take the meter reading. In that way you automatically set a correct aperture-speed combination on the camera according to the prevailing light conditions. In case the index-mark is in between two speeds **let it click into position** opposite the figure next to it.

The VITOMATIC provides this refinement with the new Prontor SLK-V diaphragm shutter in the special version, coupled with the built-in photo-electric exposure meter.

▶ Setting the Film Speed

Fully press in the lever (20), and turn the front milled rim (see white arrow) of the universal setting ring (5) until the required film speed figure appears in the DIN or ASA window (12). Release the lever again, and the front rim is once more coupled with the universal setting ring. A comparison table of film speed systems is given on page 27.

▶ Taking the Meter Reading

Point the camera at the subject, and turn the universal setting ring (5) to the left or right until the round tip of the setting marker (18) co-incides with the exposure meter needle (19), as shown in the illustration on the right. Take care, however, not to obscure the honeycomb cell window (7) with your finger.

You will find further useful hints on taking exposure readings on pages 23 to 27.

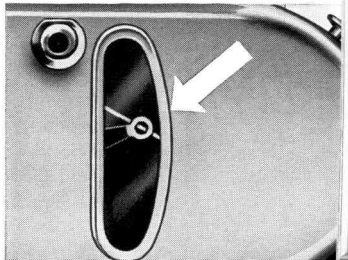
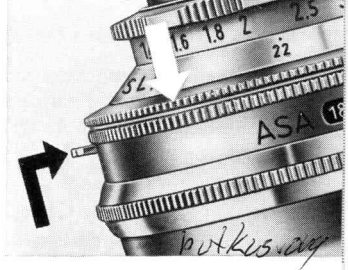

➤ The Aperture-Speed Settings

By taking the exposure reading as described on the previous page, you have at the same time set an aperture-speed combination to suit the prevailing light conditions. You can now shoot, unless you wish to use a different shutter speed (e.g. for moving subjects) or a different aperture (for greater depth of field – see page 28).

In that case simply turn the shutter speed ring (6) to the required speed or aperture; the corresponding aperture or speed respectively can be read off immediately. A single turn of the shutter speed ring thus covers the whole range of aperture-speed combinations suitable for your subject.

But please note: Once you have taken the exposure reading, do not move the universal setting ring (5) any more, otherwise the effective exposure will be altered. The same also happens if you turn the shutter speed ring (6) so that the black double index  goes beyond the left hand limit (f/22) or the right hand limit (f/2.8) of the aperture scale. In both cases the setting marker would no longer co-incide with the exposure meter needle.

● The black figures on the shutter speed scale (13) are the safe speeds for hand-held shots ($1/60$ to $1/500$ second).

● The orange figures ($1/30$ to 1 second) are also speeds which are timed automatically by the shutter on pressing the release button (9). However, at these speeds a firm support for the camera (e.g. a tripod, or a smooth supporting surface) is desirable during the exposure.

● The green figures (4 to 60 full sec.) are auxiliary values. They indicate possible exposure times when the speed ring is set to "B" (corresponding to 2 sec. as per the scale) and the diaphragm scale allows further speed-and-diaphragm combinations for poor light conditions. After selecting the appropriate combination, turn back the setting ring until the desired diaphragm figure is opposite the mark ▲ and then expose.

Such long exposure times are not foreseen in the shutter mechanism. The same as with "B", the shutter will remain open as long as the release is depressed. It is recommended to use a cable release which screws into the trigger (9) and to control the exposure time with a watch.

The Self-timer

When you have set the correct aperture-speed combination and the distance and have tensioned the shutter, set the synchronizing lever (14) to "V" (see illustration). On pressing the release, the shutter will now run down on its own after a delay of about 8 seconds, while the synchronizing lever automatically returns from "V" to "X". Do not use the self-timer when the shutter is set to green "B".

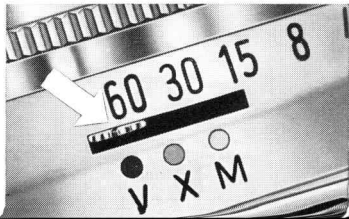

Setting the Distance

You can either estimate the subject distance from the camera, or, better still, measure it with an accessory rangefinder. The Voigtländer clip-on rangefinder is particularly suitable for this purpose. Its specially brilliant semi-reflector and robust design ensure absolute accuracy over the whole range from infinity to 3 feet.

Setting the Distance Scale

Turn the focusing ring (15) to bring the appropriate distance figure on the scale (16) opposite the \blacklozenge index mark (see illustration). Between the distance figures you will see two additional marks in red: ∇ at about 11 feet, and \bigcirc at about 33 feet. These are the zone focus settings. Warning: When rotating the distance scale, be sure not to move the universal setting ring (5) as well, otherwise you change again the exposure setting you have already determined.

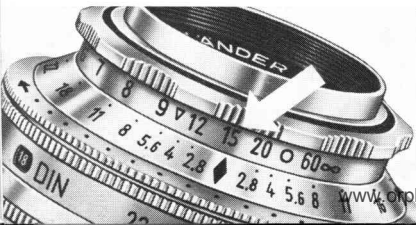

➔ Zone Focusing

Candid action shots (for instance of children at play) often yield surprisingly live pictures. On such occasions don't waste time by setting the exact distance. Instead, set the focusing scale to the near zone mark ∇ for subjects between 8 and 17 feet, and to the far zone mark \circ for subjects between 16 feet and infinity. **You must, however,** stop down to at least f/5.6 (marked in red) to ensure adequate depth of field.

Provided the light is good enough, these focusing zones are very useful when photographing sports subjects, where subject distances may change very suddenly.

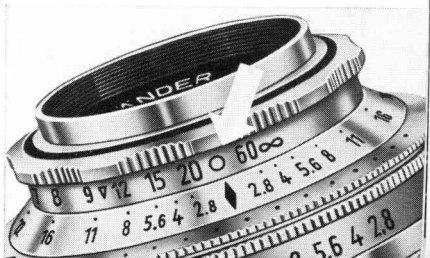
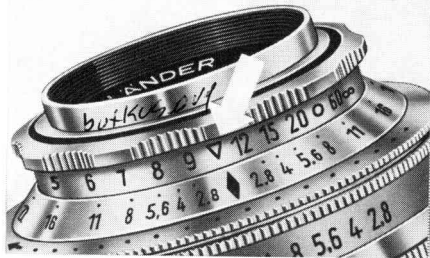

The Rapid Winding Lever



One full movement of the lever tensions the shutter, and advances the film and the film counter. A spring then returns the lever to its original position.

The rapid winder can of course also be worked in a number of short movements. In that case keep pulling the lever until it locks. An automatic lock prevents the rapid winder from being operated a second time before the shutter is released. Conversely, the shutter can only be released after operating the rapid winding lever.

This prevents both double exposures and blank frames. If the camera is empty, the rapid winder moves freely without tensioning the shutter.

Viewing and Releasing

The exceptionally large, crystal-clear Voigtländer brilliant frame finder with its unique reflected image frame shows the subject in full natural size. When viewing you can therefore keep also the other eye open (see illustration), and thus observe the surroundings of the subject as well. That is a special asset when taking candid action shots.

Please note: With subjects at about 3 feet from the camera the field of view in the finder is displaced downwards or sideways (according to whether the camera is held horizontally or upright). This is shown by the two short lines marked on the reflected image frame.

To take the picture hold the camera quite steady, and smoothly depress the release button (9). Never jab at it.

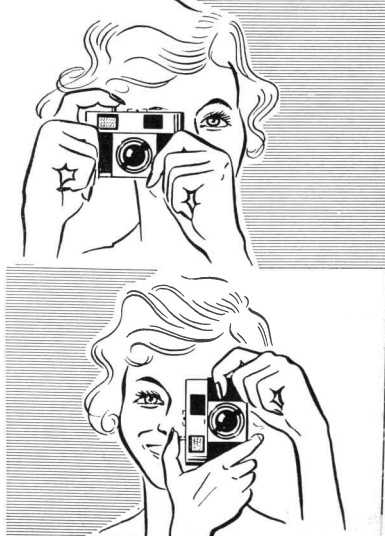

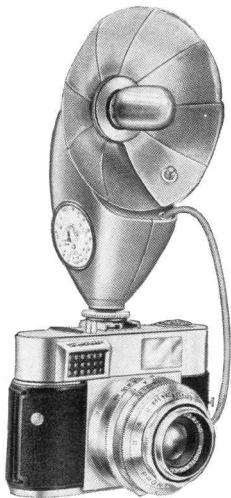

Flash Shots

The PRONTOR SLK-V shutter permits synchronized flash shots up to the fastest shutter speed of $1/300$ second with any flash gun or electronic flash unit on the market.

Please Note:

With black-and-white film the flash (clear or blue bulbs, or electronic flash) can be used on its own, or combined with daylight or artificial light sources such as tungsten lamps.

With daylight type colour film, however, only blue coated flash bulbs or electronic flash can be used as supplementary light. With the artificial light types of colour film only clear flash bulbs should be used.

Small light-weight units such as the Voigtländer battery-capacitor flash gun can be fitted directly into the accessory shoe (10) of the camera (see illustration on the left). Larger flash guns or the flash holders of electronic flash units are generally fitted to the side of the camera by means of a special bracket.

The flash cable completes the electric circuit between the flash unit and the camera shutter. Push the plug of the flash cable into the flash socket (24), as shown in the illustration.

Warning: Never use the shutter contacts to fire flash bulbs from the usual 110 or 220 volt mains.

➔ Mounting the Flash Gun on the Camera

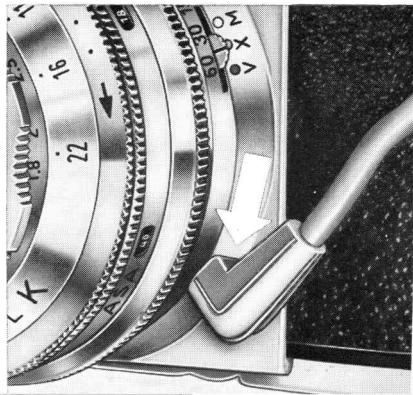

➡ Setting the Shutter and the Aperture

Flash bulbs and electronic flash units differ in their characteristics such as the firing delay and light output; the table opposite classifies them in several groups. To ensure that the peak brightness of the flash co-incides with the instant when the shutter is fully open, there are two types of synchronization: "M" and "X".

Before taking a flash shot therefore move the synchronizing lever (14) of the PRONTOR SLK-V shutter to the yellow dot marked "M" or to the red dot marked "X", as required. You can then use all types of flash and all the shutter speeds listed in the table opposite under "M" or "X" respectively. **Note:** For flash shots with the self-timer (with the synchronizing lever set to the green dot "V") use only the shutter speeds listed in the table under "X".

The lens aperture required for correct exposure can be obtained from the so-called guide number. This is usually quoted on the flash bulb packing or in the leaflets issued by the makers of the bulb or electronic flash unit. To find the correct aperture, divide the appropriate guide number by the distance in feet between the flash and the subject. In short: **Aperture = guide number : distance.**

Suitable Shutter Speeds

Flash Bulbs		Synchronizing Lever Set to	
Make	Type	X	M
Gen. Electric West Electric	} SM		
West Electric Sylvania West Electric	} SS } SF	1 to 1/125	Not suitable for M-syn- chronization
Philips Osram Philips Osram Gen. Electric Sylvania West Electric	PF 1 XM 1 PF 5 XM 5 } M-2 } 2-M	1 to 1/30	1/60 to 1/300
West Electric West Electric West Electric Gen. Electric West Electric Gen. Electric Sylvania Sylvania	0 3 } 5 } P-5 } 8 25	1 to 1/30	1/60 to 1/300
Electronic Flash Units		Synchronizing Lever Set to	
Type		X	
Instantaneous firing		1 to 1/300	

Voigtländer Filters

are made of spectroscopically tested optical glass, dyed in the mass, and coated to reduce reflections (ϕ 32 mm). The filter factors given below are approximate values, as they necessarily depend on the colour sensitivity of the black-and-white film used, and on the light conditions prevailing at the time of the exposure.

- Yellow filter G1½x** Slight filtering effect for outdoor shots requiring short exposure times, such as sports and action subjects, and pictures with low sun.
Filter factor: 1½ times.
- Yellow filter G3x** Universal filter for landscapes and other outdoor subjects, indispensable for snow pictures.
Filter factor: 3 times.
- Green filter Gr4x** Lightens green tones in landscapes. Recommended for artificial light portraiture and copying of coloured originals.
Filter factor: 4 times.
- Orange filter Or5x** Strong filter effects by considerable suppression of blue light. Reduces atmospheric haze in distant views.
Filter factor: 5 times.
- Ultra-violet filter UV** Cuts out ultra-violet radiation in high mountains or near the sea. Eliminates any unpleasant blue casts in colour shots. Requires no exposure increase.

▶ Setting the Filter Factors

The use of any filter (except the ultra-violet filter) during the exposure requires a certain adjustment of the exposure setting. With the VITOMATIC you can carry out that adjustment on the shutter. For this purpose you use the dot divisions (1) at the side of the universal setting ring (5). Mark for dot divisions is the same as for the one on the scale for depth of field ↕.

Example A: For a factor of $1\frac{1}{2}$ times turn the universal setting ring to the left by half a division in the direction of the arrow. For a factor of 3 times move it by one and a half divisions, for a factor of 4 times by two divisions, and for a factor of 5 times by two and a half divisions. In every case you therefore adjust the aperture setting according to the filter factor required. — If however the aperture-speed combination has reached the limit of $f/2.8$ on the aperture-scale, you have to turn the universal setting ring to adjust the shutter speed according to the required filter factor. Note: when setting half divisions, always set the shutter to the next longer exposure time first.

Example B: If the aperture-speed combination obtained is 1 second at $f/2.8$ (the lowest limit of exposure readings), set the filter factor as follows:

For a factor of $1\frac{1}{2}$ times advance the universal setting ring by one whole division (to "B" at $f/2.8$), turn it back half a division, and expose for $1\frac{1}{2}$ seconds.

For a factor of 3 times advance the universal setting ring by one division (to "B" at $f/2.8$) and expose for 3 seconds.

For a factor of 4 times advance the universal setting ring by one division (to "B" at $f/2.8$) and expose for 4 seconds.

For a factor of 5 times advance the universal setting ring by one division (to "B" at $f/2.8$) and expose for 6 seconds.

Close-ups with Focar Lenses

Large close-ups of small objects and animals are undoubtedly one of the most fascinating fields of photography. You can easily take these with the Voigtländer Focar lenses which are also suitable for copying book pages and small illustrations.

The unavoidable parallax error of the viewfinder in such a case can be effectively eliminated with the Voigtländer Proxirect attachment. The finder then shows the correct field of view at all subject distances between 8½ and 32 inches.

A detailed instruction booklet with data for scales of reproduction, depth of field, etc. is available on request.



Hints for Using the Exposure Meter

Generally it is sufficient to point the exposure meter at the subject from the camera position, thus measuring the light reflected from the subject. Such reflected light readings are suitable for all average subjects which show no excessive contrasts of light and shade and which are not set against an exceptionally light or dark background.

With outdoor shots, especially open views, the sky nearly always occupies part of the subject area, and thus part of the view of the exposure meter. As however the brilliant sky reflects much more light than the subject itself (the landscape, buildings, animals) it is advisable to point the camera slightly downwards when taking a reading.

Exceptions are shots of interesting cloud formations where foreground details such as buildings or figures are purposely intended to record only as silhouettes. The same applies to snow and seascapes. Pictures of people in the snow or on a brilliant beach, however, always call for close-up readings (see next page).



In some cases close-up readings are necessary for more accurate reflected light measurement. Examples are:

- Light subjects against a dark background, and vice-versa;
- Close-ups of small objects and animals;
- Nearly all pictures of people, especially portraits (see illustration).

In this case only the important parts or the subject should be used to determine the brightness range.

When taking a close-up reading, approach the subject sufficiently closely so that the selenium cell of the exposure meter only receives the light reflected by the individual subject areas. If necessary, measure two or three extreme tones, and take a medium value. Always watch that the shadow of the camera or of your own body does not obscure the part from which you are taking a reading.

Note this rule-of-thumb for close-up readings: The exposure meter should not be farther away from the measured area than the width of that area.

With tricky subjects or situations involving extreme brightness differences between the subject and its background or surroundings (e. g. against-the-light shots, snow subjects), incident light measurement is often more useful.

In that case mount the diffusing screen in front of the exposure meter window (7), and take the reading from the subject in the direction of the camera position to be used. This then measures the light actually reaching the subject. Incident light measurement is also successful with interiors with or without artificial light, for the diffusing screen extends the acceptance angle of the exposure meter.

A diffusing screen is enclosed with every VITOMATIC, and can be carried in the ever-ready case of the camera.

However, please note: With incident light readings correct exposure will of course also depend on the amount of light the subject is able to reflect. For obvious reasons it is not possible to quote any correction factors for that. You will therefore be well advised to base exposures with incident light readings on your own previous experience.

Exposure with Colour Shots

Exposure readings for colour pictures are taken in the same way as for black-and-white film. Note however that reversal colour film has a very limited exposure latitude and therefore needs specially careful readings.

To make quite certain of correct exposure — especially with reversal colour film — it is advisable to calibrate the meter for the camera and film by a few exposure tests. When you first try out a colour film therefore choose several interesting subjects and expose a frame on each one with the aperture-speed combination indicated by the exposure meter. At the same time make additional exposures of the same subject from the same viewpoint and in the same light, but giving half a stop and one whole lens stop above and below the basic setting.

Overexposure of reversal colour film yields a very light transparency which may however still be usable. Underexposure results in excessively dark images. The density of the transparencies should be judged on projection.

The VITOMATIC can be set to a range of ASA or DIN film speeds. The actual values marked are those which correspond to most colour and black-and-white films on the market (bold figures in table).

If the film is rated at an intermediate speed between two values visible in the ASA or DIN window, the camera should also be adjusted to an intermediate setting. For instance with a 16/10° or 17/10° DIN film let the setting ring (see page 9) click into position between the figures 15 and 18.

For films rated according to other speed systems (BS degrees, Scheiner, Weston, etc.) use this table to obtain corresponding values for setting on the camera.

Comparison of Film Speed Systems

DIN /10°	ASA Index	BS Log Index	European Scheiner	American Scheiner	Weston
11	10	21°	22°	16°	8
12	12	22°	23°	17°	10
13	16	23°	24°	18°	12
14	20	24°	25°	19°	16
15	25	25°	26°	20°	20
16	32	26°	27°	21°	24
17	40	27°	28°	22°	32
18	50	28°	29°	23°	40
19	64	29°	30°	24°	50
20	80	30°	31°	25°	64
21	100	31°	32°	26°	80
22	125	32°	33°	27°	100
23	160	33°	34°	28°	125
24	200	34°	35°	29°	160
25	250	35°	36°	30°	200
26	320	36°	37°	31°	250
27	400	37°	38°	32°	320
28	500	38°	39°	33°	400

Aperture and Depth of Field

The depth of field covers that part of the subject area in front of, and behind, the focused distance which appears acceptably sharp in the picture. The extent of this sharp zone is by no means constant: it increases the more you stop down the lens, and decreases the larger the lens aperture. In short:

Large apertures (e.g. $f/4$) **yield limited depth of field;**

Small apertures (e.g. $f/11$) **yield greater depth of field.**

The available depth of field zone is easily determined. After you have set the lens to the correct subject distance, look at the depth of field scale (11). This carries two series of aperture numbers arranged symmetrically to the left and to the right of the \blacklozenge index. The depth of field then extends from the distance marking opposite one of the left hand aperture figures to the distance marked opposite the corresponding right hand aperture figure (see the illustration of zone focusing on page 13).

Care of the Camera and Lens

Successful results and long life of your VITOMATIC depend largely on proper care and correct operation.

- Therefore always handle the camera gently, and never use force. In particular, protect the camera against hard knocks, and do not drop it. If you travel by car, do not keep the camera in the glove compartment or on the rear parcel ledge. In the long run such a "vibration test" will not do the built-in photo-electric exposure meter any good.
- For cleaning the lens use only a soft fluffless cloth. However, first remove coarse particles of grit (or sand at the seaside) carefully with a soft sable brush. Finger marks or other traces of grease on the lens surface can be removed with a piece of cotton wool moistened with pure alcohol or ether.
- In the case of any trouble consult your photo dealer, or post the camera to the Voigtländer agent in your country or to the Service Department, Voigtländer A.G., Braunschweig, Western Germany.

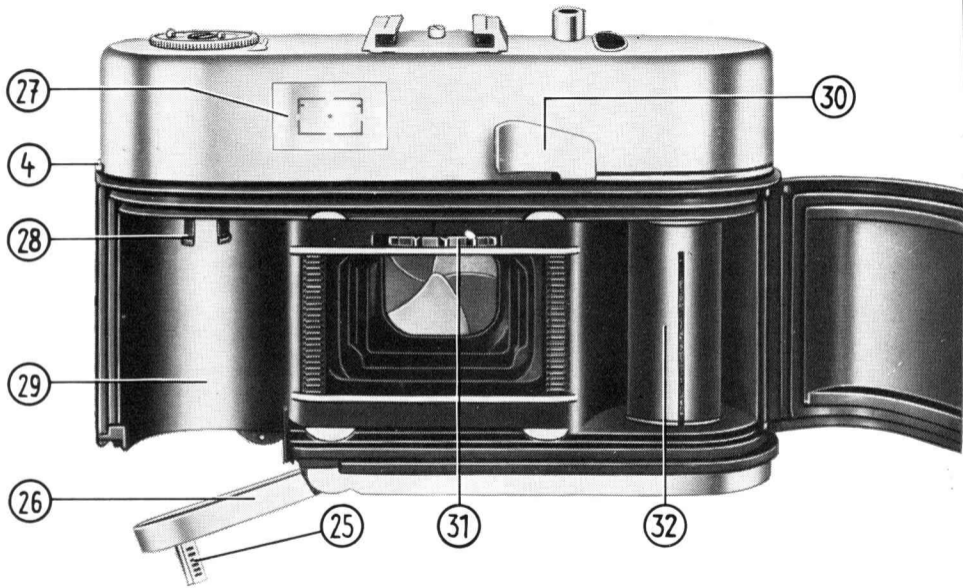

- 4 **Reversing lever**
- 5 **Universal setting ring** for exposure readings, combined with film speed setting ring
- 6 **Shutter speed ring** for setting the correct aperture-speed combination after taking the exposure reading
- 20 **Lever** to uncouple the film speed setting ring (see No. 5)
- 21 **Milled film counter setting knob**
- 22 **Film counter window**
- 23 **Tripod bush**
- 24 **Flash socket**
- 25 **Base plate latch**
- 26 **Base plate flap**
- 27 **Viewfinder eyepiece**
- 28 **Shaft of rewind knob**
- 29 **Casette chamber**
- 30 **Rapid winding lever** to advance the film and cock the shutter
- 31 **Sprocket to operate shutter, film counter and double interlock**
- 32 **Take-up spool**

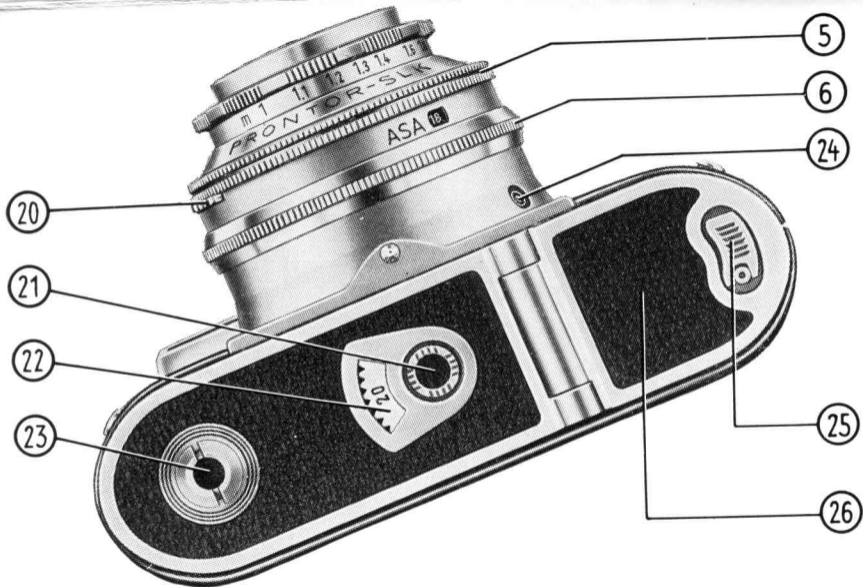

Care of the Camera and Lens

Successful results and long life of your VITOMATIC depend largely on proper care and correct operation.

- Therefore always handle the camera gently, and never use force. In particular, protect the camera against hard knocks, and do not drop it. If you travel by car, do not keep the camera in the glove compartment or on the rear parcel ledge. In the long run such a "vibration test" will not do the built-in photo-electric exposure meter any good.
- For cleaning the lens use only a soft fluffless cloth. However, first remove coarse particles of grit (or sand at the seaside) carefully with a soft sable brush. Finger marks or other traces of grease on the lens surface can be removed with a piece of cotton wool moistened with pure alcohol or ether.
- In the case of any trouble consult your photo dealer, or post the camera to the Voigtländer agent in your country or to the Service Department, Voigtländer A.G., Braunschweig, Western Germany.